

## **Bodies in Equilibrium**

Recall Newton's First Law: if there is *no* unbalanced force on a body (i.e. if  $F_{\text{Net}} = \mathbf{0}$ ), the body is in equilibrium. That is, if a body is in equilibrium, then all the forces on it must add up to equal zero; there is no resultant net force vector.

Based on this law, a body can be in equilibrium (i.e.,  $F_{\text{Net}} = \mathbf{0}$ ) under two conditions:

- It is stationary – this is known as *static equilibrium*.
- It is moving at a constant speed in a straight line – the object is in *dynamic equilibrium*.

However, even if these two conditions exist, an object still may not be truly in equilibrium. For example, the term “stationary” refers to an object that remains in place, not travelling from one position to another – the net force is zero. But if those forces act in different places on the object, it could start to rotate in place.

Consider two students pushing with equal force on opposite sides of a desk. Looking top-down on the desk:

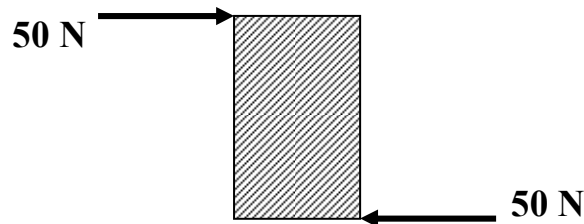

You can see that although the forces cancel out, the desk will still move, by rotating. In order for these opposing forces to truly prevent motion, they must act along the same line:

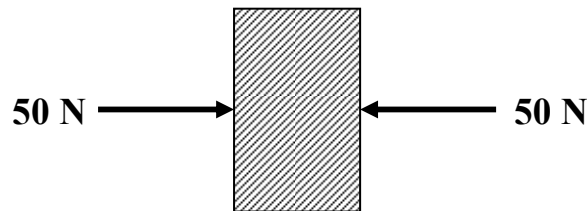

To be more specific, if the line of action of each force acting on the body passes through a common point, the forces are termed *concurrent*. This is true regardless of how many forces act on the body.

It can therefore be stated that if the net force on an object is zero, and if all the forces that act on the object are concurrent, then the object is in both *static* and *rotational equilibrium*.

For now, we will only look at simple three-force problems. When three concurrent forces act on an object that is in static equilibrium, the vector addition (tip-to-tail) diagram of these 3 vectors forms a **triangle**. Problems such as these should be solved in the following manner:

- Identify the common point where forces act concurrently.
- Draw a free-body diagram of the force vectors to show their orientation. This should look somewhat like a “Y” shape.
- Use the “tip-to-tail” method to draw a vector triangle; the tricky part here will be to label angles correctly.

Consider the following problem: a sign is supported by two cables at equal angles as shown in the diagram. Find the tension in each cable. The sign weighs  $1.0 \times 10^3 \text{ N}$ , and the cables make an angle of  $50^\circ$  with the support.

Note: tension is a pulling force only. Cables or ropes can *only* provide tension.

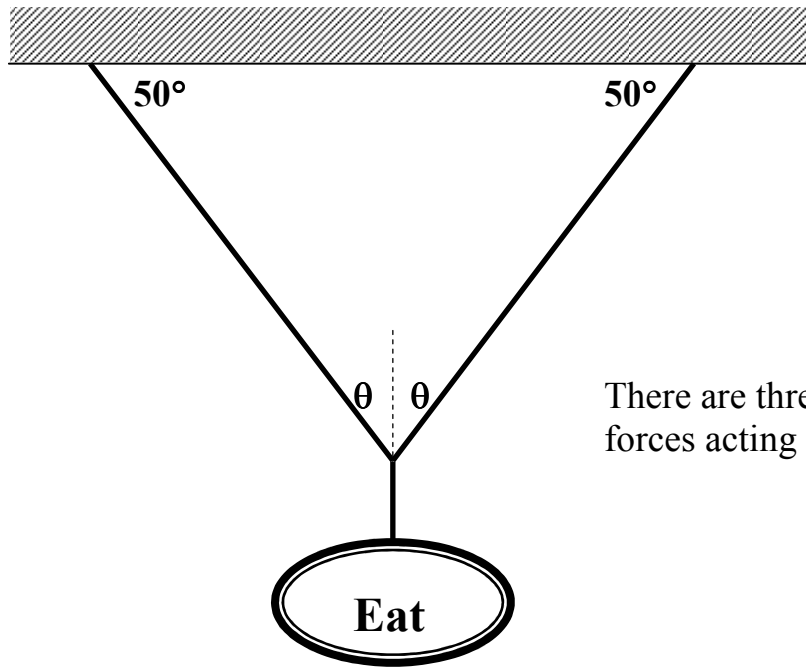

There are three concurrent forces acting on point ‘P’.

free-body diagram of forces:

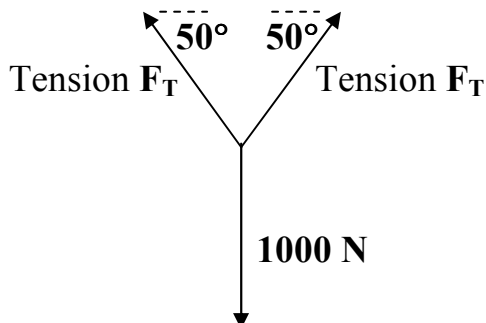

Resultant vector triangle:

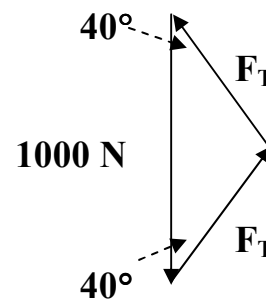

In this case both sides  $F_T$  are equal because we have an isosceles triangle. As well, by examining the vector triangle, we are given one side and the two included angles and asked to find one of the other sides. Therefore, use the Sine Law to solve (check formula sheet for reference):

$$\frac{a}{\sin A} = \frac{b}{\sin B} \quad \frac{T}{\sin 40^\circ} = \frac{1000}{\sin 100^\circ} \quad \rightarrow \quad T = 6.5 \times 10^2 \text{ N}$$

An alternate solution is to solve using components in the 'x' and 'y' directions. Note the following:

- $\square X_{\text{left}} = \square X_{\text{right}}$
- $\square Y_{\text{up}} = \square Y_{\text{down}}$

In each of the following examples, start by labelling the point where forces act concurrently, then draw the f.b.d., then the triangle with correct angles before solving.

**Example # 1. Find the tension  $F_T$  in the horizontal cable.**

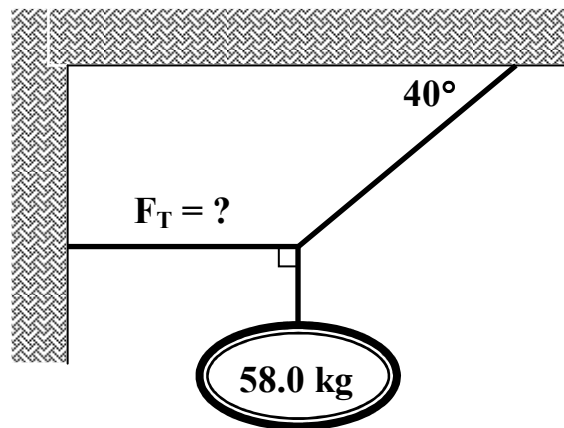

(see Equilibrium Ex 1 for answer)

**Example #2. In this case, the left cable is strong, but the right cable can only handle a maximum tension of  $5.0 \times 10^2 \text{ N}$ . What is the heaviest weight that can be hung?**

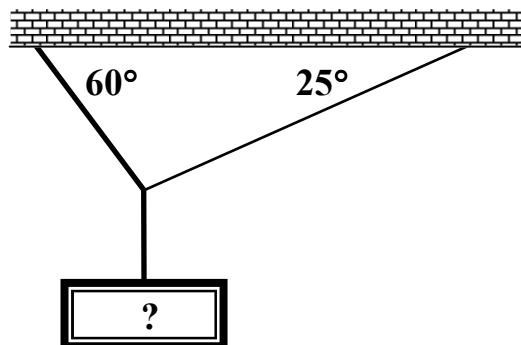

(see Equilibrium Ex 2 for answer)

**Example #3.** A large mass of 50 kg is supported on the end of a rope and the rope is pulled back by a horizontal force so that the rope makes an angle of  $80^\circ$  with the ceiling to which the rope is attached. Make a forces diagram showing all the forces involved. Use this diagram to calculate what horizontal force is needed to pull the mass out this far.

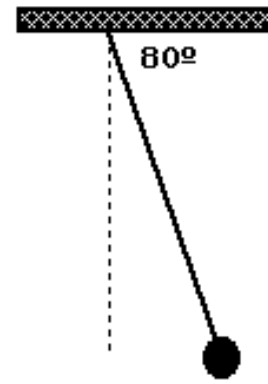

(see Equilibrium Ex 3 for answer)

Note that the force you are trying to find in order to hold an object in place is called the *equilibrant*. Sometimes, the forces in a situation do not add up to zero, and therefore are not in equilibrium, but would be if we added just one more force. To find that force in a concurrent forces situation (a) add up all the forces acting to find the resultant net force. (b) The equilibrant must be equal to this resultant, but in the opposite direction.

**Example #4.** These three forces act on a ball, as shown. Find:

- the unbalanced force on the ball;
- the force that needs to be added to cause the ball to be in equilibrium.

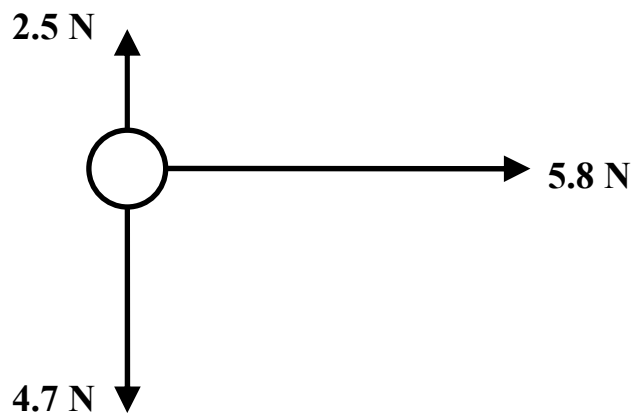

(see Equilibrium Ex 4 for answer)

**Example #5.** A cable that can withstand a maximum tension of 850 N is strung across two walls. A pulley is placed on the cable, and various masses are hung from the pulley, causing the cable to sag. Through trial-and-error, it is found that the cable can only sag  $17^\circ$  without breaking. What mass was used to cause this sag? Note that a pulley can only change the direction of a cable; the tension on either side remains the same.

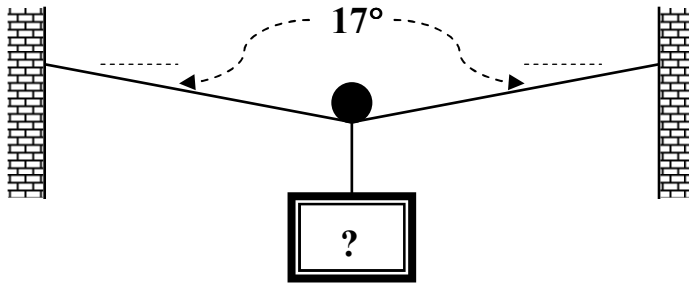

(see Equilibrium Ex 5 for answer)

**Example #6.** Now we'll take the previous example and vary it slightly. In the case below, the system is in equilibrium. Determine the unknown angle as indicated.

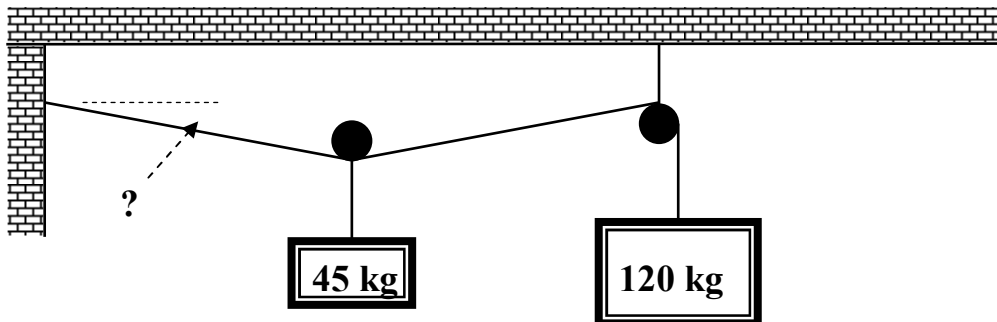

(see Equilibrium Ex 6 for answer)

## The Concept of Torque

Think back to the introduction of the last section of notes. There, you learned that if an object has two or more forces acting on it *and* these forces do not act at exactly the same point, then the object will spin, or rotate. The twisting effect of a force is called *torque*.

**Torque  $\tau$  = (applied perpendicular force) x ( distance to pivot)**

$$\tau = \mathbf{F} \times \mathbf{d} \text{ (measured in Newton-meters, or N-m)}$$

Consider the diagram below. A wrench is used to turn a nut clockwise. For the nut to turn, a force of 45 N acts perpendicular to a distance of 0.12 m from the center of the bolt – i.e., the *pivot* point about which the wrench will turn.

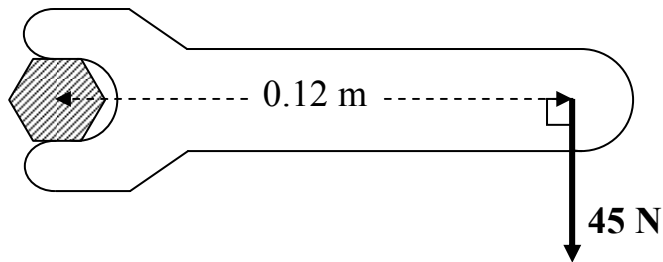

The torque here is calculated to be  $\tau = 45(0.12) = 5.4 \text{ N-m}$ , in a *clockwise* direction. Note the following:

- to calculate torque, you must be able to identify where the system will rotate (the pivot), as well as how far away from the pivot the perpendicular force acts.
- torque can be increased or decreased by changing the force that acts on the wrench.
- torque can also be increased or decreased by changing the distance that the force acts away from the pivot; this is why a longer wrench can turn a “tough” nut more easily than a short wrench – the longer wrench produces a greater torque.
- since torque causes rotation, it must be described in terms of *clockwise* (cw) or *counterclockwise* (ccw) motion.

Once more important point: a torque can only occur if the acting force is perpendicular to the distance from a pivot. This should not surprise you; after all, what would happen if the force on the wrench above was acting parallel to the distance from the pivot?

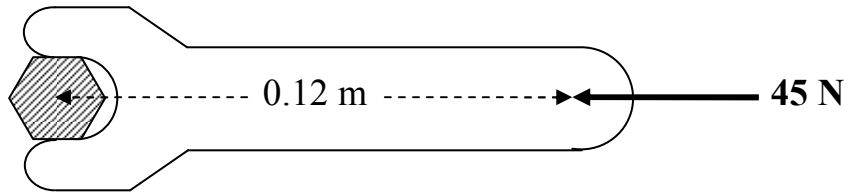

Clearly, the wrench won't turn in this case (though it might break if the force is large enough). In other words, no torque will happen in this arrangement.

What happens if the same force acts at some angle to the distance from the pivot, as shown below?

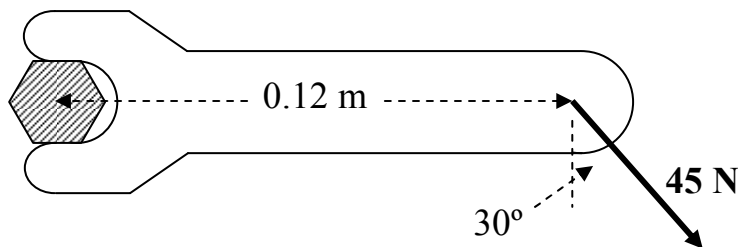

The wrench will turn, but with a reduced torque. To determine the magnitude of this torque, components of the force vector must be taken that are parallel and perpendicular to the distance from the pivot:

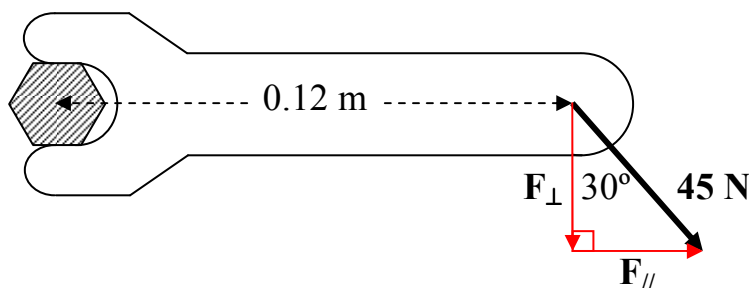

- The parallel component  $F_{\parallel}$  produces no torque and can be ignored.
- The perpendicular component  $F_{\perp}$ , which provides the torque to turn the wrench, can be calculated:

$$F_{\perp} = 45 \cos 30 = 39 \text{ N} \quad \rightarrow \quad \text{torque } \tau = 39(0.12) = 4.7 \text{ N}\cdot\text{m}$$

**Example #7.** A smart physics student attempts to lift a heavy crate by using a lever system. She pushes on the lever with a force as shown below. What torque is created by this student?

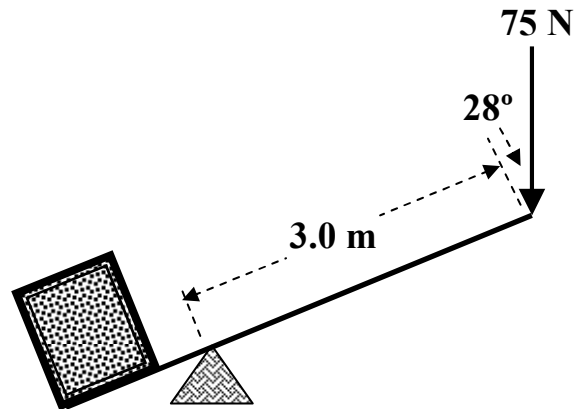

(see Equilibrium Ex 7 for answer)

One last point: *clockwise* rotations around a pivot oppose *counterclockwise* rotations around the same pivot. To determine the net torque on a system, you need to compare the total clockwise torques to total counterclockwise torques. If one is greater, the system will start to rotate.

To summarize: in tackling torque problems, it is always best to:

- identify the pivot (more on this later);
- calculate each torque (using trig if necessary to find perpendicular force components);
- classify each torque as 'cw' or 'ccw' and add or subtract accordingly to find the net torque.

**Example #8.** A group of physics students attempt to balance a mobile unsuccessfully. Examine the diagram below and calculate the net torque on the large beam that will cause the mobile to start tilting in one direction once it is hung up.

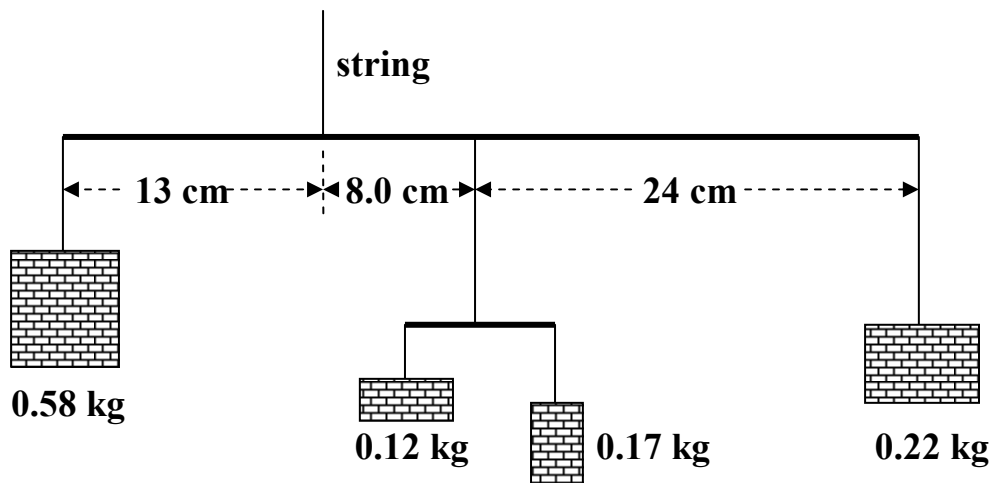

(see Equilibrium Ex 8 for answer)



## Centre of Gravity and Torque

A classic example of a torque arrangement is the teeter-totter balance. Weights placed on one side of the balance pivot provide a torque to rotate the balance one way. To counter this, weights are placed on the other side of the pivot to provide a torque in the opposite direction. You may even have performed this lab in Physics 11.

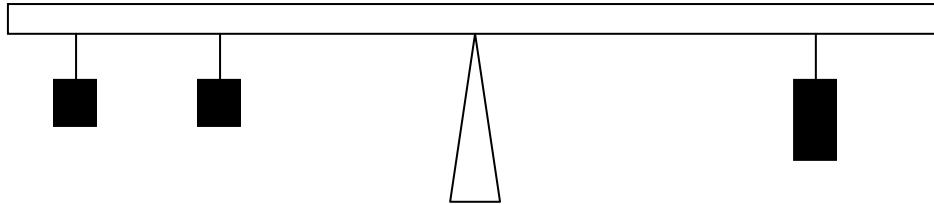

When calculating torque here, the weight of the three hanging masses must be determined, along with their respective distances from the pivot. However, one weight which is being overlooked is the weight of the beam itself, which can be ignored so long as:

- the beam is so light that its weight and resultant torque can be ignored; or
- the beam is of a *uniform* shape so that the pivot can be placed at the centre of the beam, creating balance before weights are added to either side.

However, sometimes the pivot may not be placed at the centre of a uniform beam:

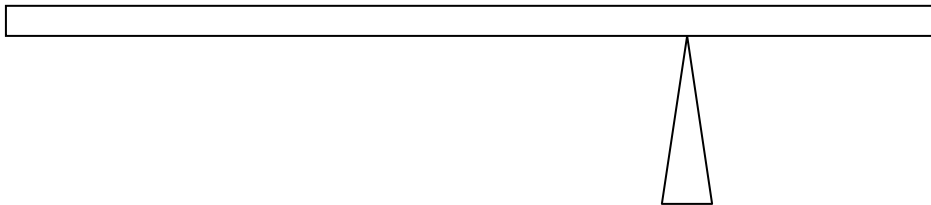

Or perhaps the beam itself is not of a uniform shape:

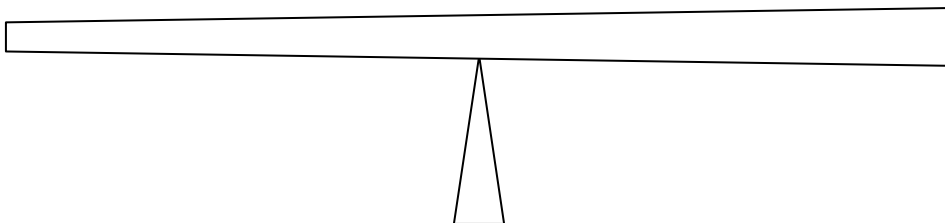

In each of these two situations, it seems clear that rotation will occur due to the weight of each beam. In order to calculate the torque that causes each rotation, the following must be known:

- the weight of the beam;
- the *centre of gravity* of the beam, in order to determine the distance of the weight away from the pivot.

The centre of gravity is simply the location where an object will have its weight evenly distributed on either side. When the object is rotating in air or space, it will do so about its centre of gravity. When a pivot is placed at this location, the object will be balanced, and no torque will occur.

Knowing the location of the centre of gravity of any object is useful, because it allows you to place the weight vector at that location, which in turn allows you to calculate the torque created. Note that the centre of gravity is always located at the mid-point of any uniform object.

For a uniform beam:

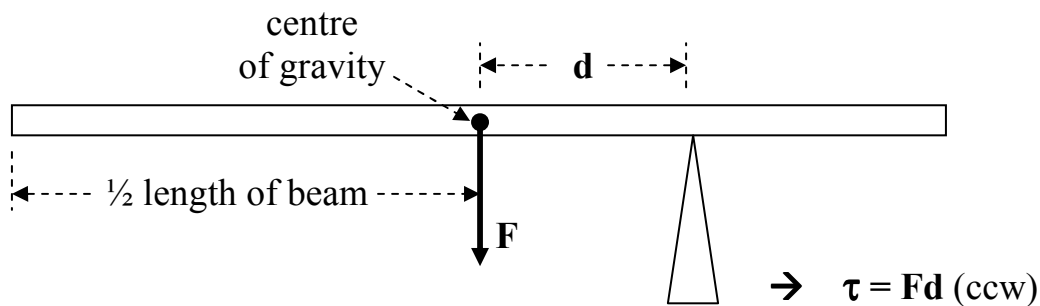

For a non-uniform beam (centre of gravity must be indicated in the question):

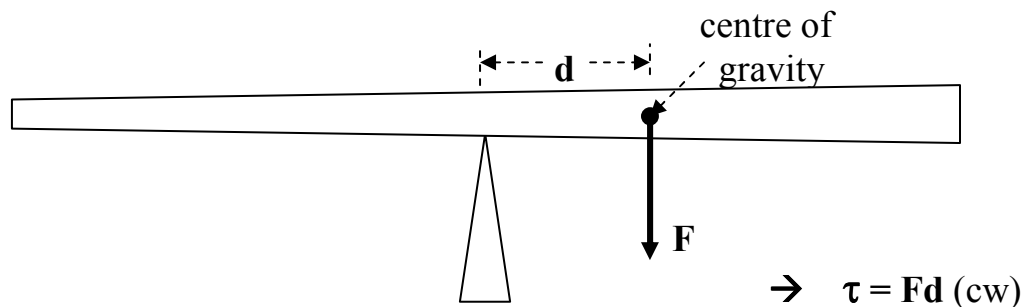

**Example #9:** Calculate the net torque acting in the system below. Note that the beam is uniform, has a mass of 0.85 kg, and a length of 6.2 m.

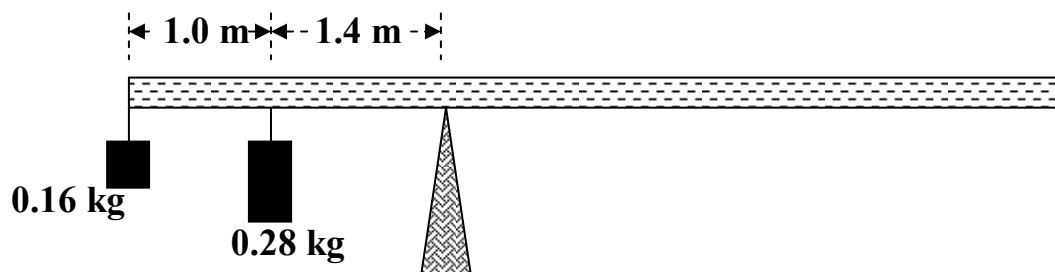

(see Equilibrium Ex 9 for answer)

Now let's review the idea of non-concurrent forces. Non-concurrent forces occur not only on beams, but also on three-dimensional objects such as heavy crates that are pushed along the floor. As before, if the line of action of each force does not pass through a common point, then a net torque may exist, causing the object to start to rotate and ultimately tip over.

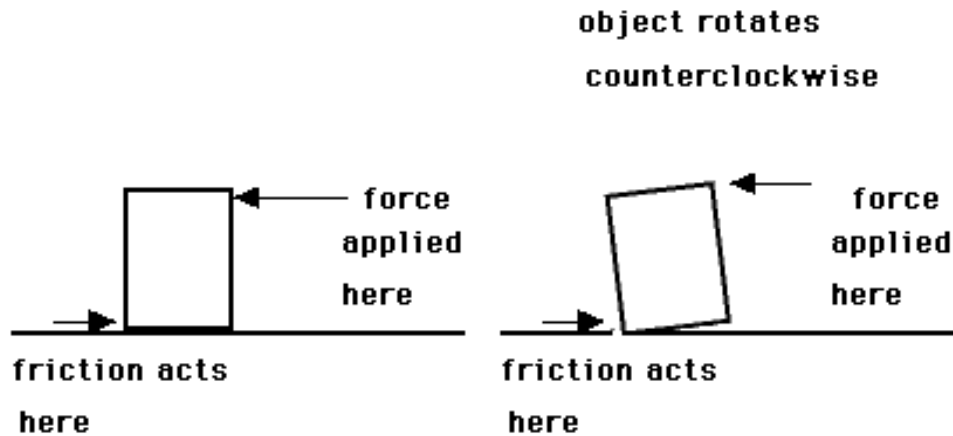

In the example above, the applied force produces a counter-clockwise torque about the lower-left corner pivot, while the centre-of-gravity of the object creates a clockwise torque about the same pivot. If the applied force is large enough, or high enough up from the pivot, the object will rotate in a counterclockwise direction, pivoting around its lower-left corner.

Note that as the object starts to tilt, both the friction force (shown in the diagram) and the normal force (not shown) act at the pivot. Therefore, these two forces produce no torque.

**Example #10.** A physics student applies a horizontal force of 480 N in an attempt to move a 150 kg refrigerator, but unfortunately causes the fridge to tip over. Examining the diagram below, what is the net torque that causes the refrigerator to begin to topple over?

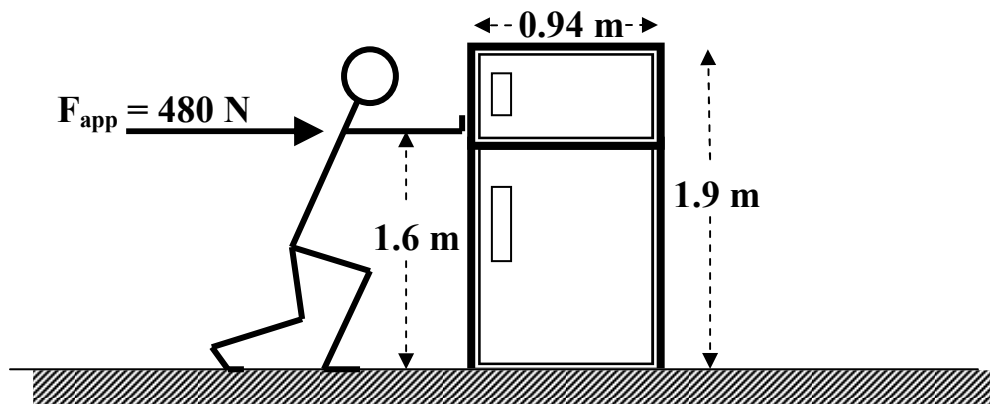

(see Equilibrium Ex 10 for answer)

## **Torque and Equilibrium**

In the notes “bodies in Equilibrium”, it was stated that static equilibrium can only truly exist if the net force is zero and if there is no net torque. In particular, if no rotation is to occur, the clockwise and counterclockwise torques must cancel each other out.

Since no rotation occurs, ANY POINT may be selected to be the pivot about which torques are calculated. Usually the pivot is selected to be where some unknown force acts. This effectively eliminates that force from the calculation, and simplifies the problem (remember, forces have no ‘torque effect’ at the pivot).

For non-concurrent forces, if no translational and no rotational motion is to occur, both conditions of equilibrium must be met:  $\tau_{\text{Net}} = 0$ ,  $F_{\text{Net}} = 0$

$$(1) \text{ sum of the y axis forces} = 0 \quad \rightarrow \quad \Sigma y = 0$$

$$\text{sum of the x axis forces} = 0 \quad \rightarrow \quad \Sigma x = 0$$

$$(2) \text{ sum of the torques} = 0 \quad \rightarrow \quad \Sigma \tau = 0$$

$$\rightarrow \quad \text{that is,} \quad \Sigma \tau_{\text{cw}} = \Sigma \tau_{\text{ccw}}$$

When a system is in equilibrium, and forces are non-concurrent, follow these steps to solve:

1. Determine as many forces as you can that act in the diagram. This may involve finding the weight of various masses, or using  $F_{\text{Net}} = 0$  to analyze unknown forces.
2. Choose a pivot where unknown and un-wanted forces are acting, to eliminate them from any torque calculations.
3. Determine the distances away from the pivot for each remaining force, including the centre-of-gravity force for the beam.
4. For any forces not perpendicular to the length of the beam (or the distance away from the pivot), use trig to find the perpendicular component for each force.

For the following four examples (11-15), the pivot should be located where the beam is attached to the wall or floor, so the frictional and normal forces acting on the beam can be ignored in your torque calculations.

**Example #11.** A 5.0 kg uniform bar is attached to the wall as shown below, with a 2.0 kg weight hung in the indicated location. What minimum vertical force is needed to cause the system to be in rotational equilibrium?

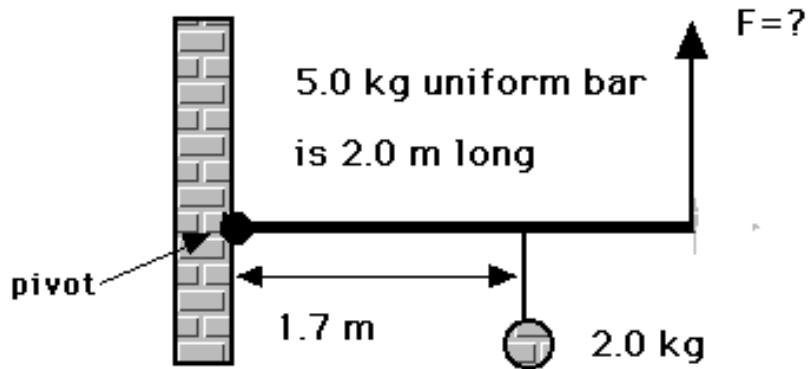

(see Equilibrium Ex 11 for answer)

**Example #12.** In the following diagram, the 1.6 m-long uniform bar has a mass of 5.0 kg. Calculate the tension "T" of the cable supporting the 20 kg mass hanging on the end of the beam.

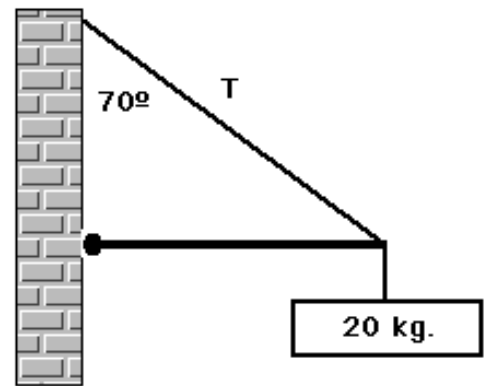

(see Equilibrium Ex 12 for answer)

**Example #13.** A 8.00 kg uniform beam of length 3.00 m is attached to a wall by a hinge and is supported from the ceiling by a rope which makes an angle of  $60^\circ$  with the horizontal, as shown below. Calculate the tension in the rope that supports the beam.

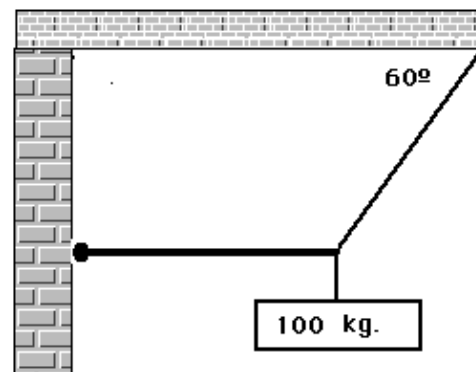

(see Equilibrium Ex 13 for answer)

**Example #14.** The 12.0 kg uniform boom below has a length of 3.40 m. The cable can withstand a tension ' $F_T$ ' of 1850 N before breaking. What is the largest weight that can be hung from the boom in the location indicated?

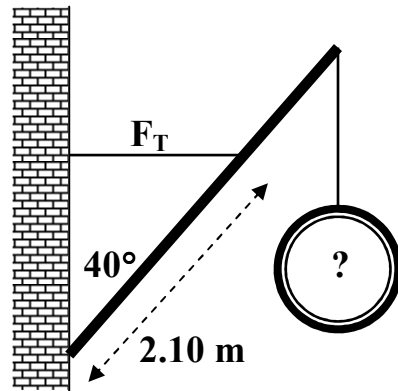

(see Equilibrium Ex 14 for answer)

**Example #15.** In the diagram below, the uniform boom has a mass of 25.0 kg and a total length of 6.50 m. If the 150 kg mass hangs 4.75 m from where the boom is anchored to the ground, how much tension ' $F_T$ ' is in the cable that supports this system?

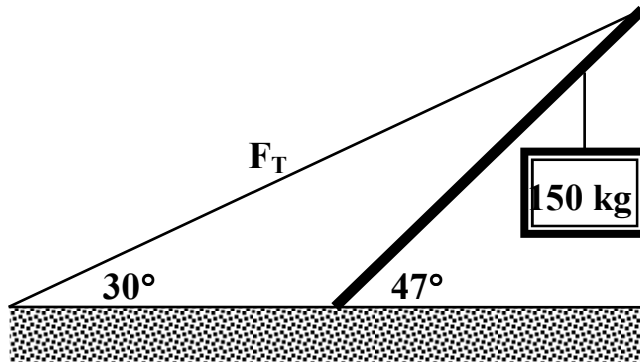

(see Equilibrium Ex 15 for answer)

**Example #16.** Two students, Phreddie and Phreida Physics, are carrying Normie Neutron on each end of a 20.4 kg uniform plank that is 3.00 m long. If Normie's mass is 51.0 kg and he is sitting 1.00 m from Phreida, how much lifting force does each student use to carry Normie?

**Hint:** take the pivot at one end in order to remove the force supplied by one student from the situation.

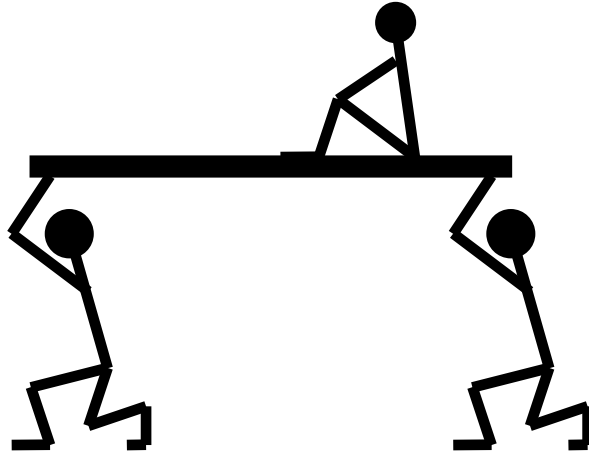

(see Equilibrium Ex 16 for answer)

**Example #17.** What force, applied half way up the block, will just start the 22 kg block tipping?

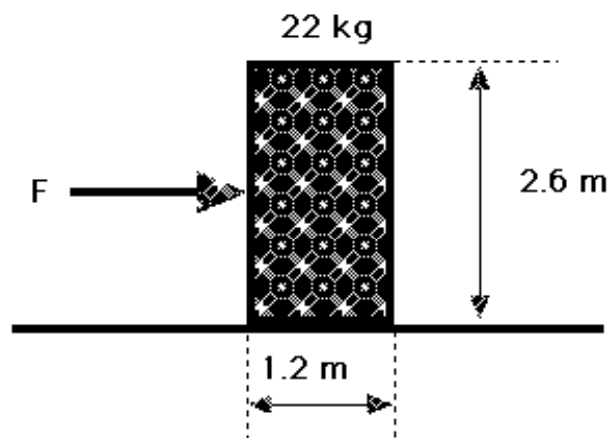

(see Equilibrium Ex 17 for answer)

For this final question, you will need to consider both aspects of static equilibrium, that is,

- $\mathbf{F}_{\text{Net}} = \mathbf{0}$  in both the horizontal and vertical direction;
- $\Sigma \tau_{\text{cw}} = \Sigma \tau_{\text{ccw}}$

Start by examining a free-body diagram of all the forces acting on the ladder. Then choose your pivot for the ladder at the floor, to eliminate the two forces acting there.

**Example #18.** A uniform 20.0 kg, 5.00 m-long ladder leans against a smooth (frictionless) wall as shown. Find:

- a) the normal force of the floor pushing up against the ladder;
- b) the normal force of the wall pushing against the ladder;
- c) the friction force between the ladder and the floor;
- d) the overall force that the floor exerts on the ladder.

**Note:** A frictionless surface can only exert a normal force – i.e., a force in a direction that is perpendicular to its surface.

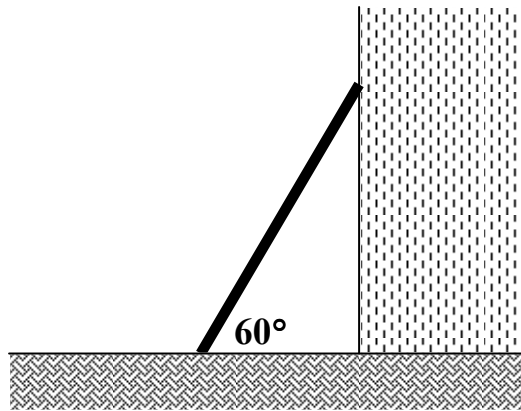

(see Equilibrium Ex 18 for answer)