

# Circular Motion and Gravitation Notes

## 1 – Centripetal Acceleration and Force

This unit we will investigate the special case of kinematics and dynamics of objects in **uniform circular motion**.

First let's consider a mass on a string being twirled in a horizontal circle at a constant speed.

Let's determine the speed of the object.

Remember that speed is defined as:

We define the period of motion (T) as the time it takes to complete one rotation.

How far does it travel in one rotation?

We can find the circumference of the circular path (distance traveled) by:

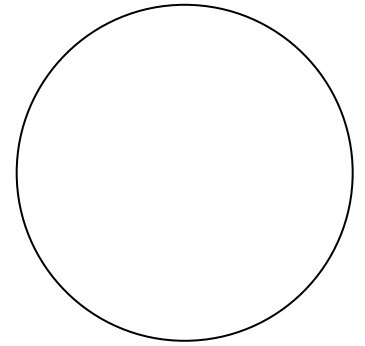

Therefore the speed of an object in uniform circular motion is:

Ok so we've figured out its speed, but is the mass accelerating?

Remember that the mass is traveling at a constant speed. However, acceleration is defined as:

So how does the **velocity** of the mass **change** with respect to **time**?

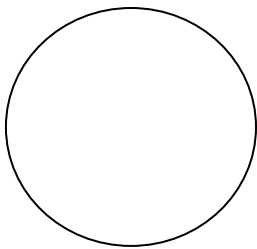

Notice that the direction of the velocity at any time is ...

So even though it may be traveling at a \_\_\_\_\_ anything traveling in a circular path is \_\_\_\_\_ because the \_\_\_\_\_ of its velocity is always changing.

The acceleration of an object in uniform circular motion is:

Let's do a quick derivation of this formula:

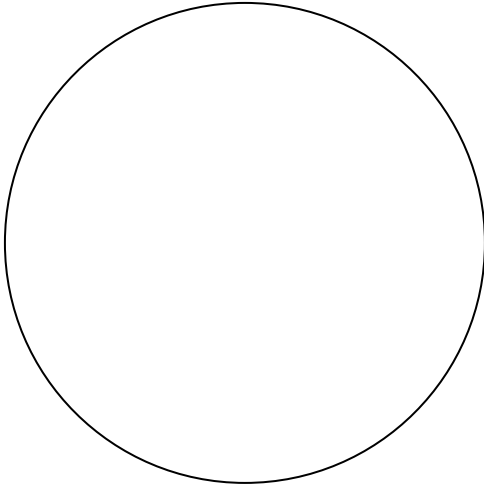

It is worth noting from the above derivation that the direction of the change in velocity is always....

Therefore the acceleration of an object in circular motion is always towards the...

This is the definition of **centripetal**, which means **center-seeking**.

Whenever an object is accelerated there must be a...

This force is known as **centripetal force**,  $F_c$ . This is not a new force, it is simply the **net force** that accelerates an object towards the center of its circular path.

Examples:

1) A mass is twirled in a circle at the end of a string, the centripetal force is provided by

\_\_\_\_\_

2) When a car rounds a corner on a highway, the centripetal force is provided by

\_\_\_\_\_

3) When the Moon orbits the Earth, the centripetal force is provided by

\_\_\_\_\_

Newton's Second Law we can help us to determine a formula for centripetal force:

Example:

Calculate the centripetal force acting on a 1.5 kg object whirling at a speed of 2.3 m/s in a horizontal circle of radius 0.60 m?

Example:

A car traveling at 14 m/s goes around an unbanked curve in the road that has a radius of 96 m. What is its centripetal acceleration?

What is the minimum coefficient of friction between the road and the car's tires?

Example:

A plane makes a complete circle with a radius of 3622 m in 2.10 min. What is the speed of the plane?

One last note on a little thing called **centrifugal** force. While centripetal means center- \_\_\_\_\_ centrifugal means center- \_\_\_\_\_.

Centrifugal force is actually an *apparent* force - it does not exist. It is simply the apparent force that causes a rotating object to move in a straight line.

However, Newton's First Law tells us that we do not need a force to keep an object moving in a straight line, you only need a force to *deflect* an object from moving in a straight line.

In reality what we seem to feel as centrifugal force is really...

Example:

When riding in the backseat of a car that is turning a corner, you slide across the seat, seeming to accelerate outwards, away from the center of the turning circle.

In reality your forward inertia you had before the car started to turn makes you want to continue in a straight line.

It is not until you slide into the side door and it exerts a centripetal force (normal force in this case) that accelerates you towards the center of the turn.

## Circular Motion and Gravitation Notes

### 2 – More Centripetal Problems

We have already seen the forces acting on a mass moving in a horizontal circle, now let's see how this differs from a mass moving in a vertical circle.

Draw the forces acting on a mass on a string being spun in a vertical circle at the top and bottom of its path.

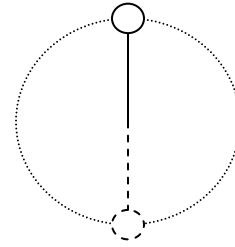

As with any object moving in a circle there is a \_\_\_\_\_ acting on it.

This net force is a centripetal force.

Notice that at the top of its arc the centripetal force (or net force) is:

Also at the bottom of the arc the centripetal force is:

Now suppose the mass is spun with just enough speed to keep it moving in a circular path. What is the tension in the string at the top?

We say that the mass at the peak of the arc is **weightless**, because the net force working on it is only \_\_\_\_\_. This is the same as an object in total free fall.

#### Example:

An object is swung in a vertical circle with a radius of 0.75 m. What is the minimum speed of the object at the top of the motion for the object to remain in circular motion?

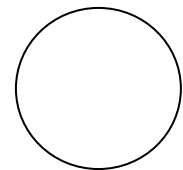

Notice that the velocity of the object...

it depends only on...

For the special case of finding the minimum speed of an object at the top of its circular arc we can use the equation:



Example:

A 1.7 kg object is swung from the end of a 0.60 m string in a vertical circle. If the time of one revolution is 1.1 s, what is the tension in the string:

a) at the top?

b) at the bottom?

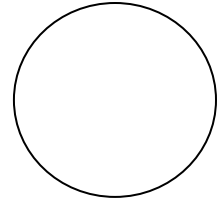

Banked Curves (and other 2-D Problems):

When cars travel at high speeds on highways, they do not rely solely on friction to keep the cars from sliding off the road. A greater centripetal force can exist if the turn is banked.

Consider a car traveling at a constant speed around a frictionless banked corner.

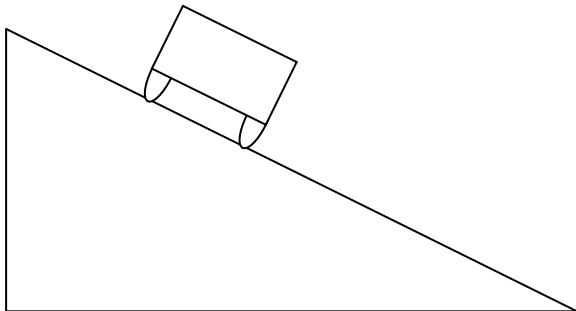

On a frictionless corner only \_\_\_\_\_ and \_\_\_\_\_ act on the car.

Note that in this case  $F_N$  is larger because it both:

(1)

(2)

The sum of  $F_N$  and  $F_g$  must equal \_\_\_\_\_

Example

Calculate the angle at which a frictionless curve must be banked if a car is to round it safely at a speed of 22 m/s if its radius is 475 m.

Example

A 0.25 kg toy plane is attached to a string so that it flies in a horizontal circle with a radius of 0.80 m. The string makes a  $28^\circ$  angle to the vertical. What is its period of rotation?

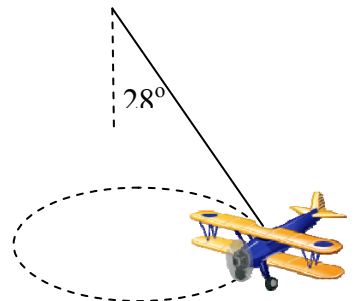

# Circular Motion and Gravitation Notes

## 3 – Gravitation

Newton discovered that gravity attracts any two objects depending on their \_\_\_\_\_ and their \_\_\_\_\_.

$F_g$  is proportional to the two masses

$$F_g \propto$$

$F_g$  is inversely proportional to the square of the distance between their centers of mass

$$F_g \propto$$

or

Where:



### Example

Calculate the force of gravity between two 75 kg students if their centers of mass are 0.95 m apart.

### Common Question Alert!!!

You will often see problems that ask something like this...

A satellite weighs 9000 N on Earth's surface. How much does it weigh if its mass is tripled and its orbital radius is doubled?

While we're at it, let's make sure we clear up another common misconception: mass vs. weight.

Mass:

Weight:

### Satellites in Orbit

A satellite of the Earth, such as the moon, is constantly falling. But it does not fall towards the Earth, rather it falls *around* the Earth. Just as if you were in an elevator that was falling towards the Earth you would feel weightless if you were on an artificial satellite falling around the Earth.

Consider the Moon:

Example: A 4500 kg Earth satellite has an orbital radius of  $8.50 \times 10^7$  m. At what speed does it travel?

# Circular Motion and Gravitation Notes

## 4 – Gravitational Fields

Scientists had difficulty explaining how two objects that are not in contact can exert a force on one another. In order to help conceptualize how this can occur, we had invented the idea of *FIELDS*.

A field is defined as...

To help imagine how these fields work, consider a **campfire**. It seems as though the fire is emitting a *heat field*.

As you approach the fire the ...

As you increase the size of the fire the ...

Just like this so-called heat field, gravitational fields surround any mass. Fields can be described as either **vector** or **scalar**.

While heat is measured by temperature (a scalar) its field is also scalar. Gravitational fields are **force fields** and as such are \_\_\_\_\_.

Vector fields, like vector quantities, are represented by arrows. In this case, the density of the arrows represents the magnitude of the field strength...



We are already quite familiar with gravitational field strength by its other name: \_\_\_\_\_.

Recall that:  $F_g = mg$

Therefore



Where  $g$  = acceleration due to gravity  
= gravitational field strength  
=  $9.80 \text{ m/s}^2$  near Earth's surface

This formula works fine if we stay put on Earth, but it falls way short once we leave Terra Firma because...

However, we can derive a more useful formula:



Example:

What is the gravitational field strength on the surface of the Moon?

$$m_{\text{moon}} = 7.35 \times 10^{22} \text{ kg}$$

$$r_{\text{moon}} = 1.74 \times 10^6 \text{ m}$$

Example:

A satellite orbits the Earth at a radius of  $2.20 \times 10^7 \text{ m}$ .  
What is its orbital period?

Geosynchronous Orbit

The orbital speed of a satellite will depend on the strength of gravitational field at the orbital radius.

Consider the following situations. Which identical satellite will be travelling faster in each case? Why?

- a) Satellite A orbits the Earth at twice the orbital radius of Satellite B.
  
- b) Satellite A orbits the Sun at the same orbital radius that Satellite B orbits the Earth.

The orbital period of the satellite depends only on the mass of the planet and the orbital radius of the satellite. It stands to reason therefore that at a certain orbital distance the orbital period will match the rotational period of the planet. Such a satellite is said to be in geosynchronous (or geostationary) orbit.

Example:

Find the orbital radius of a satellite that is geostationary above Earth's equator.

What is the speed of this satellite?



## Circular Motion and Gravitation Notes

### 5 – Potential Energy, Satellites and Escape Velocity

#### Gravitational Potential Energy

We have already discussed gravitational potential energy.

$$E_p =$$

However, as we have seen,  $g$  is not a constant but rather depends on \_\_\_\_\_ and \_\_\_\_\_.

Let's Derive!!!

$$g = \text{_____} \text{ and } E_p =$$



If you look at your formula sheet you will notice that this equation has a negative sign. What's the deal?

Whenever we talk about gravitational potential energy, we have to use a reference point. At this reference point we assign a gravitational potential energy of \_\_\_\_\_.

When determining the potential energy on a mass provided by the gravitational force generated by a second mass, we assign the ZERO reference point when the distance between the objects is \_\_\_\_\_.

This means whenever the objects get closer together the potential energy between them gets less. Compared to infinity the potential energy of the object will always be negative.

Let's sketch a graph showing the relationship between gravitational potential energy of one object relative to another and the distances between their centers.



#### Example:

A 2500 kg satellite is in orbit  $3.60 \times 10^7$  m above the Earth's surface. What is the gravitational potential energy of the satellite due to the gravitational force due to the Earth?

Note: The potential energy of this satellite relative to some infinite position is...

Example cont:

What is the **total** energy of the satellite in the last question?

Change in Potential Energy

A change in potential energy can be found by using:

$$\Delta E_p = E_{pf} - E_{pi}$$

But because of the negative sign in the  $E_p$  equation...

Example:

How much work is required to move a 4600 kg satellite from an orbital radius of  $1.8 \times 10^7$  m to a radius of  $4.2 \times 10^7$  m?

Example:

The International Space Station drops a 250 kg waste shuttle from an altitude of  $3.50 \times 10^5$  m. At what speed would it impact Earth if there were no air friction? (Assume it starts at rest)

### Launching (Escape Velocity)

What goes up must come down, unless we throw it really, REALLY hard.

Escape velocity is the minimum speed an object requires in order to break free from Earth's pull and achieve orbit. It should stand to reason that if an object is going to be completely freed from the Earth gravitational pull that we need to supply it with enough \_\_\_\_\_ to match its \_\_\_\_\_ at infinite.

In terms of equations this means that:

=

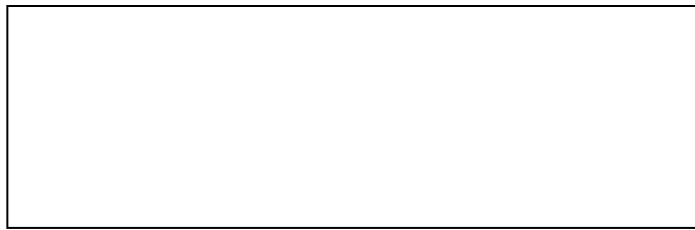

#### Example:

At what speed do you need to throw a 1.0 kg rock in order for it to leave the Earth's gravitational pull?

Does the mass of the rock matter?